

DISCOVER THE TIPPING SOLUTIONS WITH **HMLIFT**



+90 332 239 08 52



hmlift.com



info@hmlift.com

We discover!

We are always discovering
the new and the good.

We are rediscovering the earth,
our planet, our resources.

Because we are not only responsible
for our own business.

We also see our customers as our
partners, we are always looking for
new ways for them to discover
the future .

Our intention is not just to be a
world leader, but to be the leader of
a more sustainable world, We
discover innovative ideas with
technology and innovations.

In order to work more motivated and
happy with our colleagues, we also
discover their wishes and
expectations.

We want to discover all the
continents in terms of transportation.

For more, we are wondering the
highest point of a better
quality services.

Because we know that;
There is so much to discover!

Let's discover the world
together, shall we?

**DISCOVER THE TIPPING
SOLUTIONS WITH HMLIFT!**



HMLIFT

Only the company capable of producing all hydraulic
kit components under the same roof...

HMLIFT is a HIDROMAS brand.





DISCOVER THE HMLIFT EXPERIENCE!

OPERATIONAL EXCELLENCE

HMLIFT provides outstanding service by reflecting teamwork, accountability and innovation.

CONTINUOUS IMPROVEMENT

Teamwork, experience, accountability and innovation - all this is reflected in the quality of our results.

INNOVATIVE SOLUTIONS

We create products based on our experience and desire to discover.

CERTIFIED PRODUCTS

Our products are presented by having all the conditions demanded by the market.

SPECIFIC TO YOUR BUSINESS

We reduce the risk of errors while improving the quality of your work with products and solutions specific to your business.

THE POWER OF EXPERIENCE

We offer products as a result of the most advanced production technologies with long years of experience.

HMLIFT

DISCOVER YOUR BUSINESS POTENTIALS WITH OUR EXPERT TEAM!



UNIQUE SOLUTIONS

We are at your service with our experience and technological power in transportation solutions.



SPECIFIC TO YOUR BUSINESS

We reduce the risk of errors while increasing the quality of your work with products and solutions specific to your business.



FRIENDLY CUSTOMER SERVICE

We produce services for you in all pre-sales and after-sales processes.



✓ **29.000 m2**
Closed Area

50.000 m2
Total Area ✓

✓ **Total Number**
Of Staff 194

+83
Machinery ✓

*Engineers, Technicians,
White Collars, Blue Collars.

✓ **45.000**
Cylinders
per year

60.000
Pumps
per year ✓

✓ **45.000**
Valves
per year

20.000
Oil Tanks
per year ✓



HMLIFT

Our intention is not just to be a world leader,
but to be the leader of a more sustainable world,

**WE DISCOVER
INNOVATIVE IDEAS
WITH TECHNOLOGY
AND INNOVATIONS.**



 +90 332 239 08 52

 www.hmlift.com

 info@hmlift.com

WE ARE INSPIRED BY THE NATURE.



Because in the nature, everything is flawless.



 +90 332 239 08 52

 www.hmlift.com

 info@hmlift.com



HMLIFT PRODUCTS ARE FAST, POWERFUL.



Cheetas are the fastest accelerating animals in the nature.

**AS OUR
HYDRAULIC
SYSTEMS
ONLY TAKES
32 SECONDS
OF LIFTING
TIME FOR
24m³
SEMITRAILER.**



+90 332 239 08 52

 www.hmlift.com

 info@hmlift.com



**OUTSTANDING
PERFORMANCE
IN HIGH
TEMPERATURES.**



 +90 332 239 08 52

 www.hmlift.com

 info@hmlift.com

Polar bears can survive in extreme cold weather conditions down to -50C.

**OUR HIGH
QUALITY
DURABLE
PRODUCTS CAN
PERFORM IN
THE SAME
CONDITIONS
WITH EASE.**



 +90 332 239 08 52

 www.hmlift.com

 info@hmlift.com

Penguins stand 65 days for their eggs and cover them to prevent from freezing arctic conditions.

**AS WE PROVIDE
MAINTENANCE
AND REPAIR OF
OUR PRODUCTS
DURING
AND AFTER
WARRANTY
PERIOD.**



 +90 332 239 08 52

 www.hmlift.com

 info@hmlift.com

CYLINDER



HMLIFT CYLINDERS ARE MORE

- **POWERFUL**
- **DURABLE**
- **SAFETY**

K Type



Hydraulic



C Type



E Type



H Type



A Type



B Type



1 - Sealing System

HMLIFT has strategic partnership with the worldwide known sealing manufacturers. Advanced sealing system promises no oil leakage and easier service. HMLIFT cylinders are capable to work in between $-40\text{ }^{\circ}\text{C}$ / $+80\text{ }^{\circ}\text{C}$.

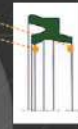
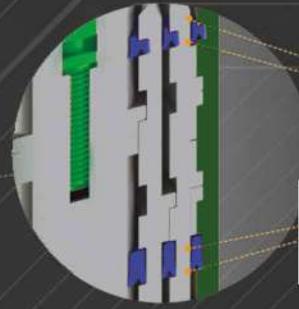

*1.lip wipes dirt and leaves residual oil film on the rod
*2.lip makes additional protection from particles

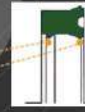

*Superior sealing effect with the secondary lip.
*Extra protection against the small particles.



2 - Solid Tubes

All tubes are %100 ST-52 cold drawn steel and internationally certificated. Our solution partners are the world leading manufacturers and providing to HMLIFT special dimension tubes for decades.

3 - Forged Steel Parts and Super Light Brackets

Trunions and spherical eyes are forged and heat treated. Reinforced casting brackets saves 7 kg weight on the chassis.

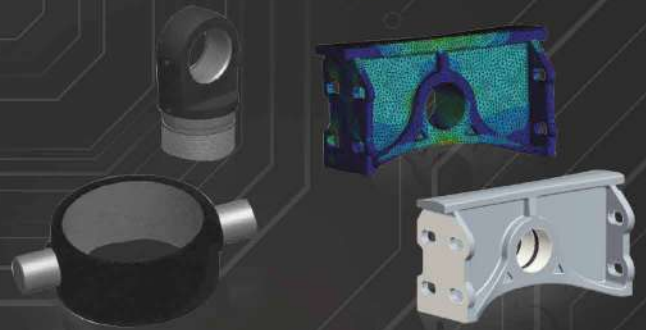

4 - Light and Strong Design

Our special tube diameters and thickness make HMLIFT series lightest and strongest in the world with %15 more lifting capacity than the others. Maximum durability and easy maintenance comes with unique HMLIFT design.



5 - Integrated Production Line with Automation

All production process is supported by robot technologies and monitored professionally by ERP and Data Base Management systems.



6 - Standart Chroming

All stages hard chromed as a standard treatment in manufactory. Minimum 50 μ chrome plating on diameter preventour products from humidity, extreme weather conditions and external involvements.



7 - %100 Process Traceability and Testing

During the production process, all parts of the cylinders moved to the next stage with extended barcode number to create the final product serial number. All cylinders put in automatic test units and tested in real working conditions. (Pressure and Load)



8 - All in One-Pack Solution with HMLIFT Hydraulic Kit

When HMLIFT cylinders are used with HMLIFT hydraulic kits, they reach

- The best performance
- Perfect compatibility with all components for easy assembly and service.
- 180.000 cycles with %50 over load. (tested)



PISTON PUMP

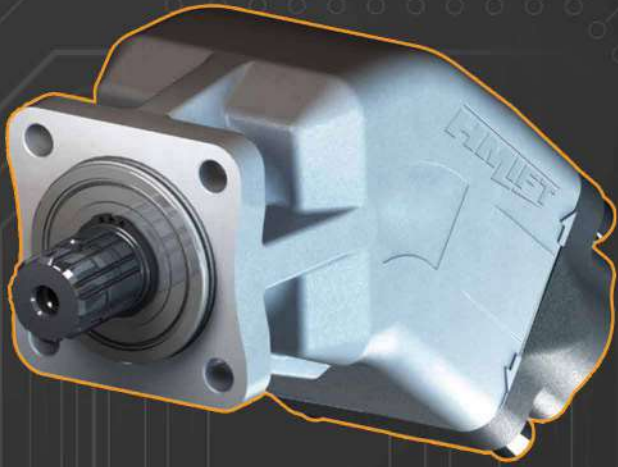

HMLIFT

REPERCUSSION OF THE SUCCESS

Bent Axis Pump

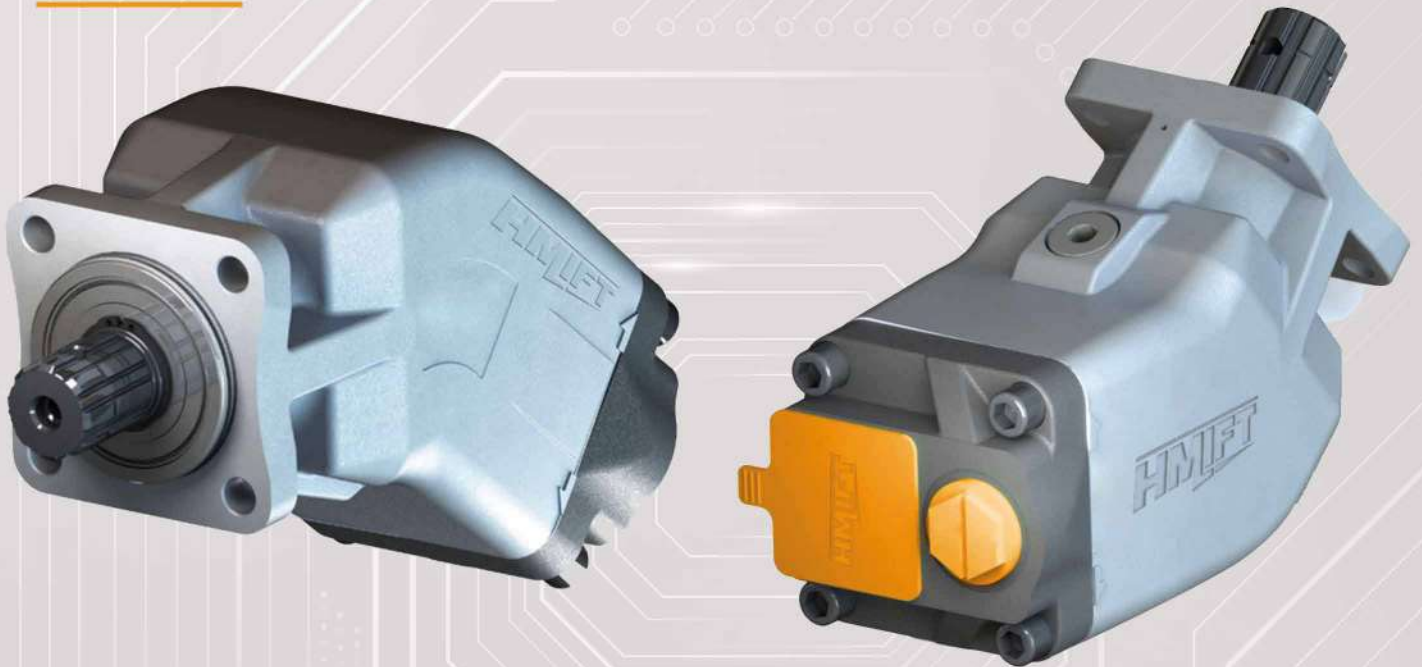

Piston Pump



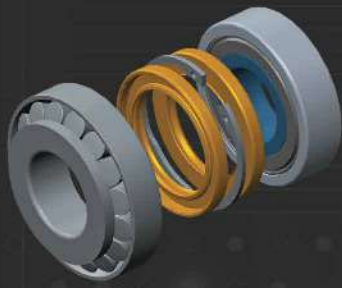

Solid Aluminum Body Unique Design Sealing

Extremely light aluminium body and premium quality sealing combined together for high pressure and high RPM applications.



Best Materials Combined For Best Results

Only best quality bearings used for HMLIFT Piston Pumps. All parts machined and assembled with great sensitivity.



Absolute Solution For Hardest Applications

HMLIFT Piston Pumps are designed and produced for hardest applications. Durability and precision are their main characteristics.

HMLIFT



%100 Testing Implemented For All Piston Pumps

Vibration and maximum pressure test reports despatched within each HMLIFT Piston Pumps.

%100 Process Traceability

During the production steps, all processed parts are delivered to the next stage within the extended barcode number. We can monitor manufacturing phases of every single product from the product serial number.

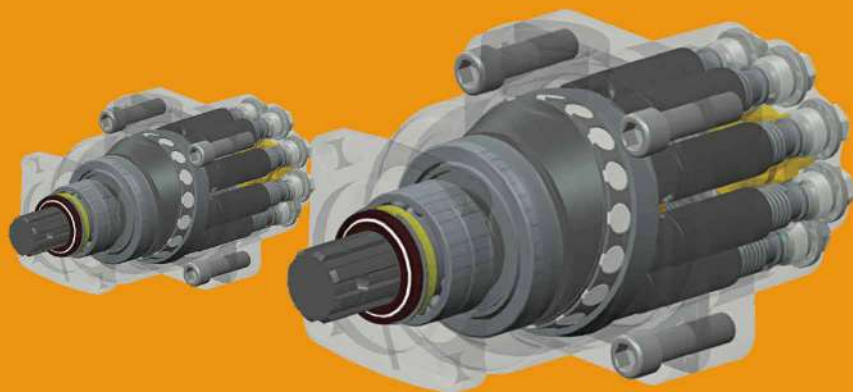

Steel Casting Body and Cover for High Pressure Resistance

Casting parts improved with special alloy to create more abrasion resistance and to rich higher performance parameters.

Quality Comes With Precision

All critical parts and machining tolerances controlled for precise compatibility.



%100 Quality Control

From raw materials to the final product, various quality controls are implemented in our laboratories.

- Gear profile analysing
- 3D coordinate measuring
- Micro structure analyses
- Tensile and corrosion tests ect.

GEAR PUMP

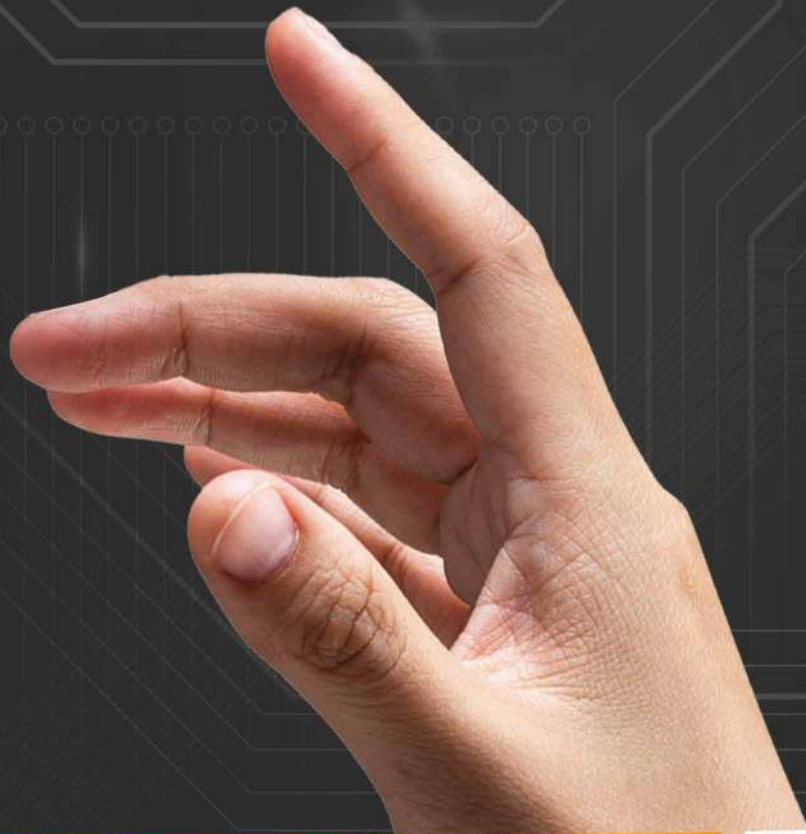

HMLIFT

**TRANSFORMING
BEST MATERIALS
TO THE BEST
PRODUCT**

HMLIFT GEAR PUMPS



HMLIFT

25 Group Gear Pump Bi-Directional



ISO



UNI
Displacement
15, 25, 35, 45 Liters

35 Group Gear Pump Bi-Directional



ISO



UNI
Displacement
75, 90, 105, 125 Liters

30 Group Gear Pumps /Rear Bi-Directional



ISO



UNI
Displacement
55, 65, 82 Liters

30 Group Gear Pumps /Side Bi-Directional



ISO



UNI
Displacement
55, 65, 82 Liters

40 Group Tandem Gear Pumps Single Directional



UNI



ISO

Displacement
63, 73, 87, 109, 133 Liters

40 Group Gear Pumps Single Directional



ISO



UNI

Displacement
87, 109, 133, 151 Liters



Perfect Working Clearance Between Gear Teeth

Special gear design provides quiet and efficient performance. Gear profiles machined with DIN level 7 standard.



Special Design Sealing and Premium Quality Bushings

No oil leakage guarantee and long life cycle.



Heath Treatment Facility

All gears has been heat treated in Plant internally with constant quality controls.

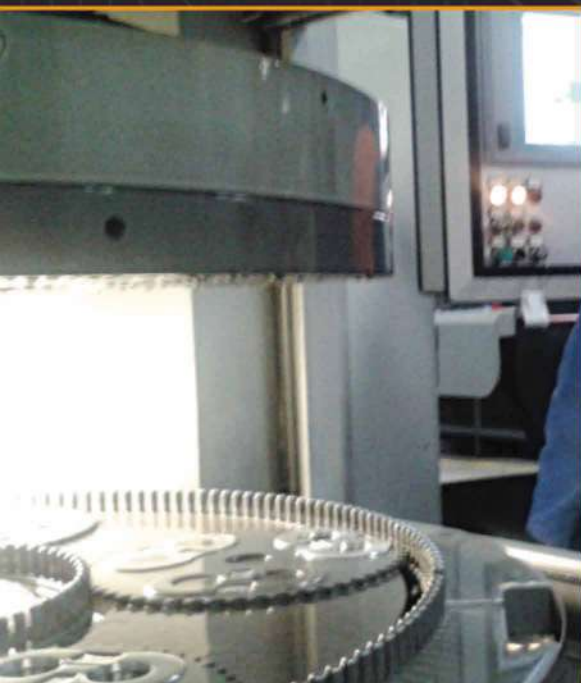

Only 0,1 Micron Surface Roughnesson Gears and Thrust Plates

Most crucial parts has been uniquely super finished with last technologies. Gear Pumps are one step ahead from other European rivals with longer life cycle and low noise emission.



%100 Testing Implemented

Vibration and maximum pressure test reports despatched within each product.

%100 Process Traceability

During the production steps, all processed parts are delivered to the next stage within the extended barcode number. We can monitor manufacturing phases of every single product from the product serial number.



Steel Casting Body and Cover for High Pressure Resistance

Casting parts improved with special alloy to create more abrasion resistance and to rich higher performance parameters.

%100 Quality Control

From raw materials to the final product, various quality controls implemented in our laboratory. (Gear profile analysing, 3D coordinate measuring, micro structure analyses, tensile and corrosion tests ect..)

HMLIFT



OIL TANK



HMLIFT

HMLIFT OIL TANKS

HMLIFT provides wide range of side mounted oil tanks with a unique design. With seamless welding and electrostatic painting HMLIFT oil tanks provide maximum performance and durability.

Side Mounted



On Chassis For Truck



On Chassis For Trailer



1- Strap Mounted Oil Tanks Wave Breakers & Rotatable T Valve

Unique design simplifies the assembly on the chassis and minimises the vibration effects.

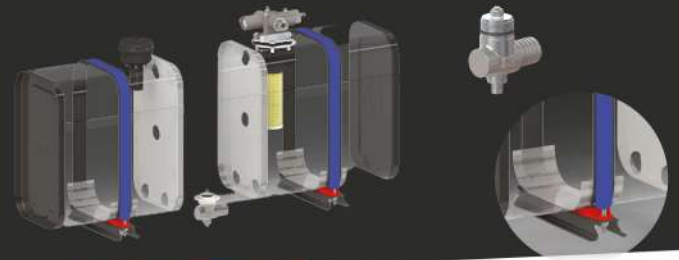

2-Seam Welded Oil Tanks Painted with Electrostatic Technology

Maximum performance
and durability with no oil
leakage guarantee.

3 - One Cradle Solutions for Any Chassis

HMLIFT oil tank cradle designed for any chassis to assemble our side mounted tanks to all truck bodies with ease.

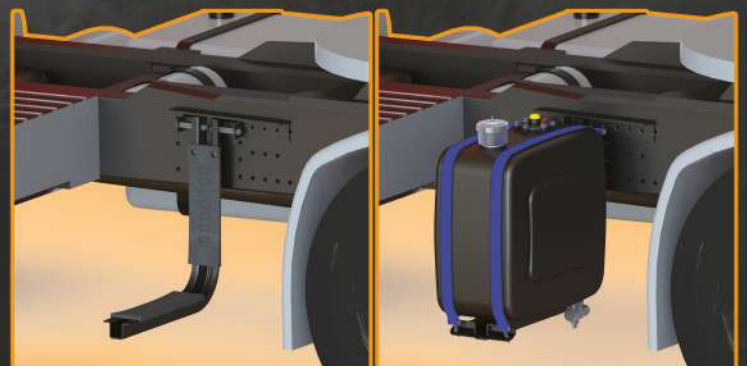

HYDRAULIC VALVE



WIDE RANGE PRODUCTION OF MOBILE HYDRAULICS

**Tipping valve / 3B -140 It
Fast Slow**



Pressure
170 / 190 bar

Tipping Valve 3B - 140 It



Pressure
170 / 190 bar

Tipping Valve / 3B-200 It



Pressure
170 bar

Tipping Valve 3B - 60 It



Pressure
170 bar

Directional Valve / Rear Door



Pressure
170 bar

Clouse Loop Valve 140 It



Pressure
170 bar

Diverter Valve



Pressure
170 bar

End of Stroke



Pressure
170 bar

HYDRAULIC KIT



+123 456 78

 www.hmlift.com

 mail@mail.com



DISCOVER HMIIFT HYDRAULIC KIT

You can contact our sales representative to find out the suitable kit for your vehicle.

Trailer Type



Truck Type



Under Body Type



1- All in One-Pack Solution

HMLIFT is the world's leading company for producing all main hydraulic kit components under the same roof such as Hydraulic Pumps, Valves, Oil Tanks. Therefore we offer you perfect compatibility and easy assembly with all in one pack solutions.



01

Three position joystick with pressure warning



03

Electronic data collection device



02

Proportional valve and pressure switch

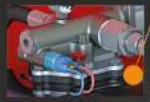

04

End of stroke valve



2- HMLIFT Four Point Safety System Maximum Safety & Optimum Operation Efficiency

Hydraulic Kits are customised according to customers' specific requirements.

3- Premium Quality Fittings & Hydraulic Hoses

All connection components are designed and quality-controlled by our engineers to assure you trouble-free operations. 2 years rust resistance guaranteed with all zinc plated couplings & vanes.



Hoses with special rubber, synthetic textiles and steel frame promises strong endurance in high pressure and extreme weather conditions.

4 - Combined Valve and Return Filter No Welding on Oil Tanks

All directional valves are available with combined return filter. With bolt joint connection, no welding required to assemble the air breather, valve, filter and T valve to the HMLIFT oil tanks



www.hmlift.com

HMLIFT



+90 332 239 08 52



www.hmlift.com



info@hmlift.com